

单相複卷變压器

WT-H種

(受注生産)

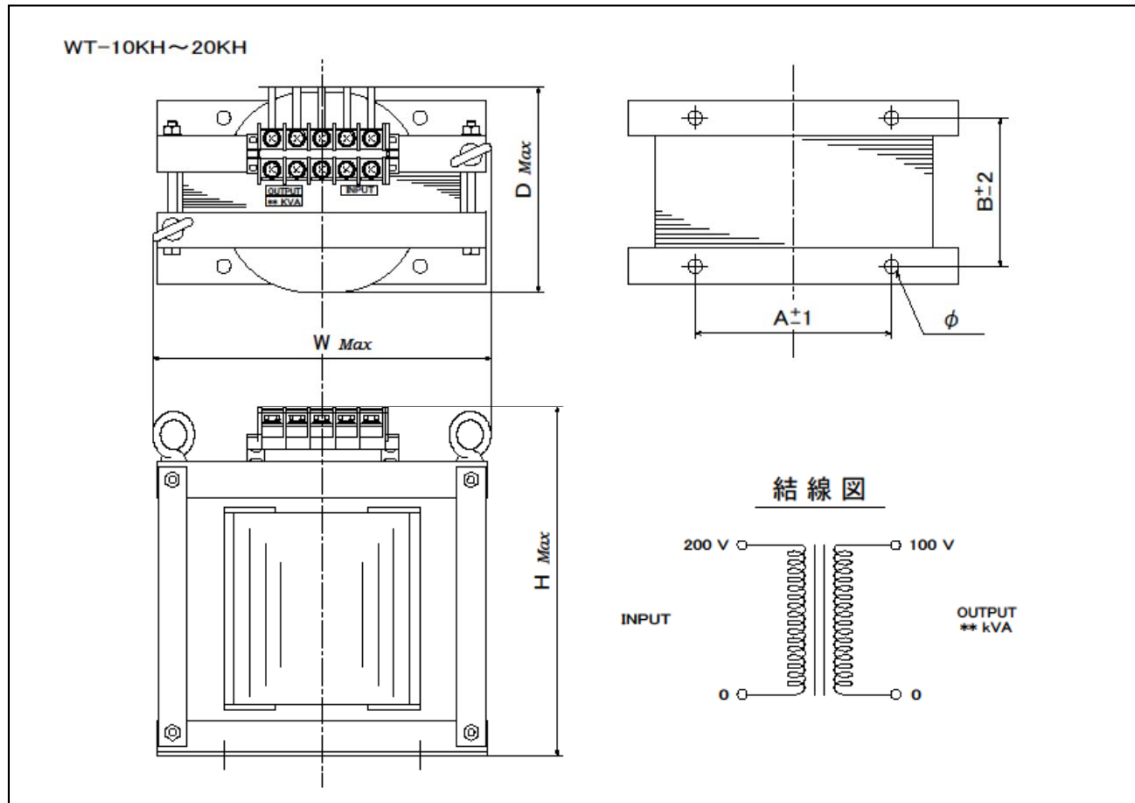

H種絶縁 概略寸法表

単位 mm

型名	容量	入力電圧/出力電圧	W	D	H	A	B±2	φ	質量 kg
WT-5KH	5 kVA	200/100 V	268	240	290	180	150	12×20	47
WT-6KH	6 kVA		268	260	290	180	170	12×20	54
WT-7.5KH	7.5 kVA		268	280	295	180	190	12×20	63
WT-10KH	10 kVA		360	240	375	240	150	13	85
WT-15KH	15 kVA		360	290	395	240	200	13	120
WT-20KH	20 kVA		360	340	435	240	230	13	161
WT-25KH	25 kVA	400/200 V	430	370	495	250	280	14	190
WT-30KH	30 kVA		430	370	525	250	280	14	213
WT-40KH	40 kVA		470	390	600	300	290	16	275
WT-50KH	50 kVA		490	410	630	300	310	16	327

单相複巻ケース入変圧器

WTC-H種

(受注生産)



WTC-5KH~20KH



WTC-5KH: プレーカーは特別注文



WTC-10KH: キャスターは特別注文

H種絶縁 概略寸法表

標準電圧 : 200 V / 100 V 又は 400 V / 200 V

塗装色 : マンセル 5Y7/1

単位 mm

型名	容量	W	D	H	E	I	C	A	B±2	φ	質量 kg	図
WTC-5KH	5 kVA	305	430	320	40	45	/	265	300	11	58	1
WTC-7.5KH	7.5 kVA	305	430	320	40	45	/	265	300	11	73	1
WTC-10KH	10 kVA	355	480	450	50	45	/	310	300	13	108	1
WTC-15KH	15 kVA	405	480	530	50	55	/	360	350	13	161	1
WTC-20KH	20 kVA	405	480	530	50	55	/	360	350	13	184	1
WTC-25KH	25 kVA	455	600	600	75	55	/	300	565	14	220	2
WTC-30KH	30 kVA	455	600	700	75	55	/	300	565	14	248	2
WTC-40KH	40 kVA	455	650	750	75	65	/	300	615	14	310	2
WTC-50KH	50 kVA	455	650	800	75	65	/	300	615	14	382	2

図 1

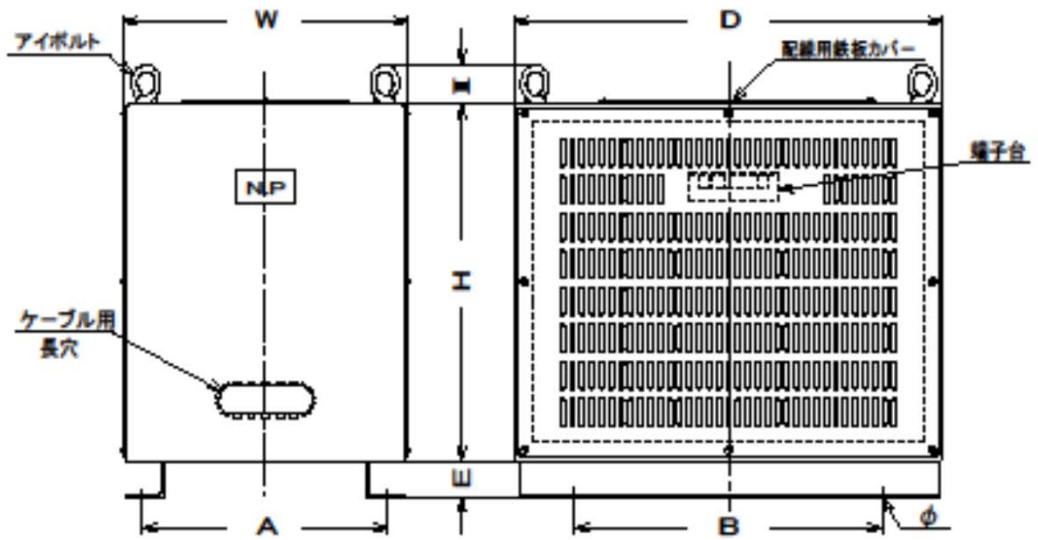

図 2

