

单相複巻変圧器

THF

(標準在庫品)

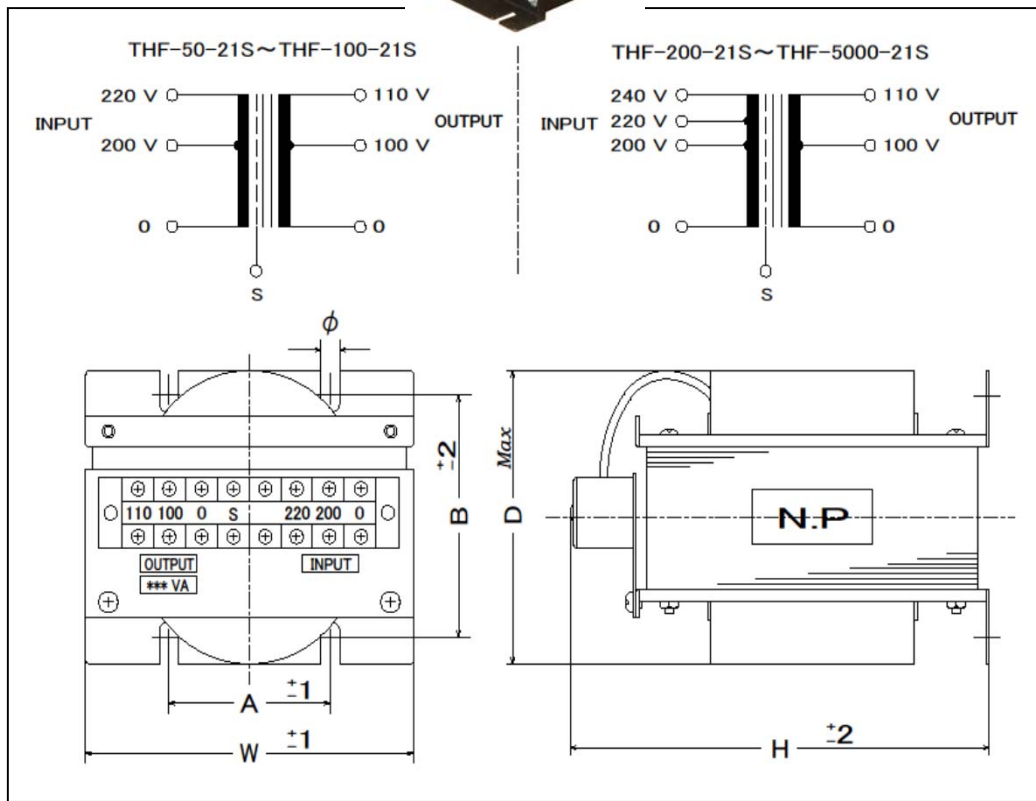

B種絶縁
寸法表

S印：一次・二次間静電シールド入

単位 mm

型名	容量	入力電圧/出力電圧	W	D	H	A	B±2	φ	質量 kg
THF-50-21S	50 VA	200,220/100,110 V	98	80	88	50	60	5	1.5
THF-100-21S	100 VA	200,220/100,110 V	98	95	96	55	70	5	2.3
THF-200-21S	200 VA	200,220,240/100,110 V	118	110	127	70	75	7	3.5
THF-300-21S	300 VA	200,220,240/100,110 V	118	130	127	70	95	7	5
THF-500-21S	500 VA	200,220,240/100,110 V	134	145	146	87	120	7	8.5
THF-750-21S	750 VA	200,220,240/100,110 V	150	140	171	98	110	8	10
THF-1000-21S	1 kVA	200,220,240/100,110 V	152	150	187	100	120	8	13.5
THF-1500-21S	1.5 kVA	200,220,240/100,110 V	184	170	175	125	140	8	18
THF-2000-21S	2 kVA	200,220,240/100,110 V	205	180	222	100	130	9×20	25
THF-3000-21S	3 kVA	200,220,240/100,110 V	220	190	236	160	140	8	33
THF-5000-21S	5 kVA	200,220,240/100,110 V	268	240	268	180	170	12×20	53
THF-50-41S	50 VA	380,400,440/100,110 V	88	85	100	55	60	5	2
THF-100-41S	100 VA	380,400,440/100,110 V	98	95	115	60	70	6	2.5
THF-200-41S	200 VA	380,400,440/100,110 V	118	110	127	70	75	7	3.5
THF-300-41S	300 VA	380,400,440/100,110 V	118	130	127	70	95	7	5
THF-500-41S	500 VA	380,400,440/100,110 V	134	145	146	87	120	7	8.5
THF-50-42S	50 VA	380,400,440/200,220 V	88	85	100	55	60	5	2
THF-100-42S	100 VA	380,400,440/200,220 V	98	95	115	60	70	6	2.5
THF-200-42S	200 VA	380,400,440/200,220 V	118	110	127	70	75	7	3.5
THF-300-42S	300 VA	380,400,440/200,220 V	118	130	127	70	95	7	5
THF-500-42S	500 VA	380,400,440/200,220 V	134	145	146	87	120	7	8.5